



Cyborg Intake System

“The World’s First Tuned air Intake System!”
 Factory safe air/fuel ratio’s for Optimum performance
 Injens tuning process covered by three U.S. Patents

Part number SP6063
2007-13 MazdaSpeed 3 2.3L
4 cyl. Turbo

- 1- Short ram intake w/heat shield
equipped with the patented Air Fusion
- 1- 2 3/4" Injen/AMSOIL (#1013)
 Ea nano-fiber dry filter
- 1- 2 1/2" X 2 3/4" step-hose (#3116)
- 2- Power-bands 040/.312 (#4003)
- 1- 15"- 15mm vacuum hose (#3079)
- 1- Composite stand-off (#15023)
- 2- m4 x 10mm button heads (#6047)
- 1- m6 flange nuts (#6002)
- 1- Fender washers (#6010)
- 1- heat shield (#HS5000BLK/P)
- 3- composite HS clamps (#4010)
- 3- 5/16"-18 x 1/2" hex bolt (#6019)
- 1- 5 page instruction

Congratulations! You have just purchased the best engineered, dyno-proven cold air intake system available.

Please check the contents of this box immediately.

Report any defective or missing parts to the Authorized Injen Technology dealer you purchased this product from.

Before installing any parts of this system, please read the instructions thoroughly. If you have any questions regarding installation please contact the dealer you purchased this product from.

Installation DOES require some mechanical skills. A qualified mechanic is always recommended.

*Do not attempt to install the intake system while the engine is hot. The installation may require removal of radiator fluid line that may be hot.

Injen Technology offers a limited lifetime warranty to the original purchaser against defects in materials and workmanship. Warranty claims must be handled through the dealer from which the item was purchased.

Injen Technology 244 Pioneer Place Pomona, CA 91768 USA

Please check the contents of this box immediately.

Warning: Manufactures attempting to duplicate Injen’s patented process will now face legal action.

MR Technology Step down process:

- 1- Calibration Method for Air Intake Tracts for Internal Combustion Engines.
 Covered under Patent# 7,359,795
- 2- Calibration Device for Air Intake Tracts for Internal Combustion Engines.
 Published and patent pending
- 3- Calibration Method and Device for Air Intake Tracts having Air Fusion Inserts
 Published and patent pending

Note: **The C.A.R.B Exempt sticker must be attached under the hood in a manner such that it is easily viewed by an emissions inspector.**

Note: Injen strongly recommends that this system be installed by a professional mechanic.

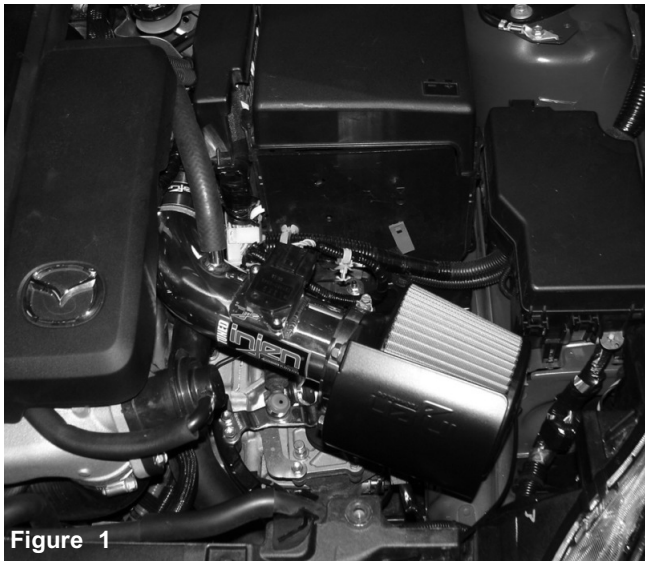

Figure 1



Figure 2

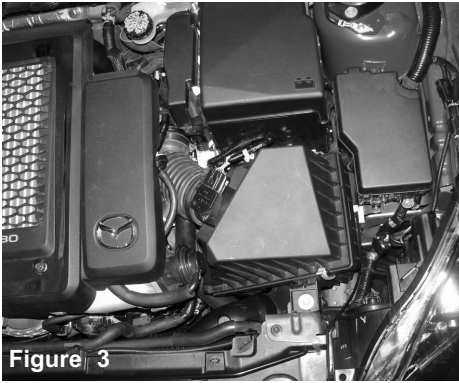

Figure 3
Stock air intake cleaner and air ducts shown in this picture. Before getting started with the installation, disconnect the negative battery terminal.

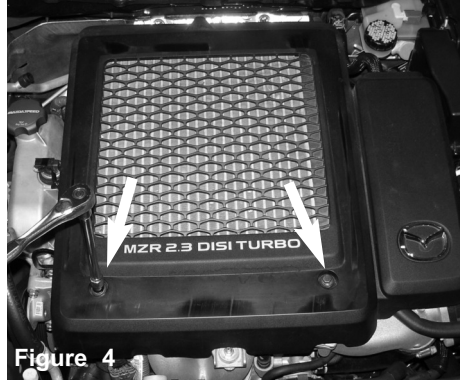

Figure 4
Loosen and remove the two m6 bolts from the inter-cooler cover.

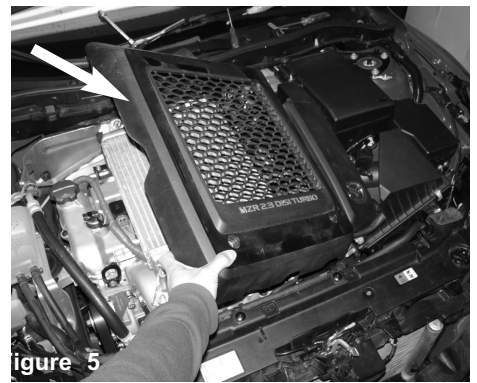

Figure 5
Once you have removed the m6 bolts, continue to remove the intercooler cover.

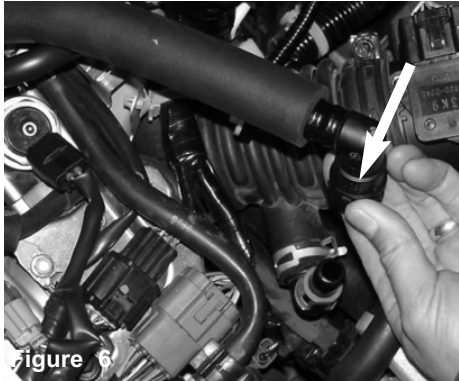

Figure 6
Press on the plastic tab over the male compression fitting and detach from the female fitting.

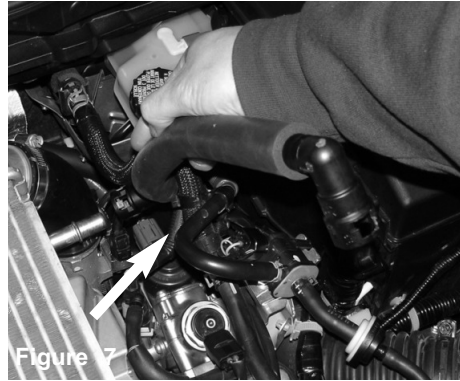

Figure 7
Repeat step 7 to remove the male compression fitting located on the crankcase port.



Figure 8
The entire crankcase vacuum hard line is now removed.

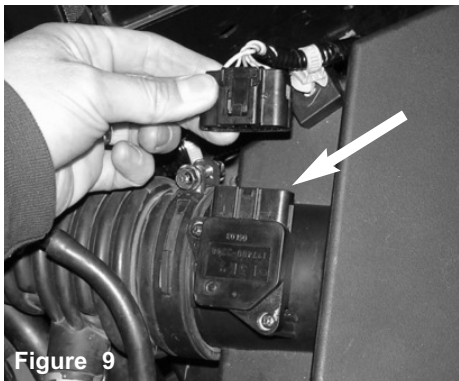

Figure 9
Press on the top plastic tab on the harness clip and detach from the mass air flow sensor.

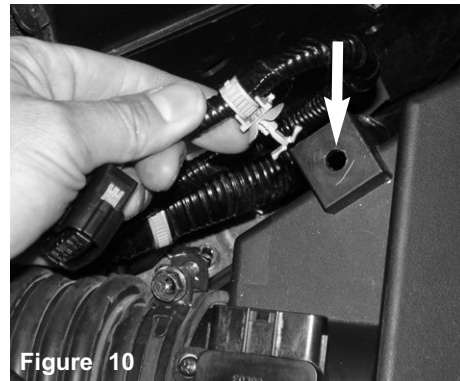

Figure 10
Using a screwdriver, pop plastic clip from the air box bracket and remove as shown above.

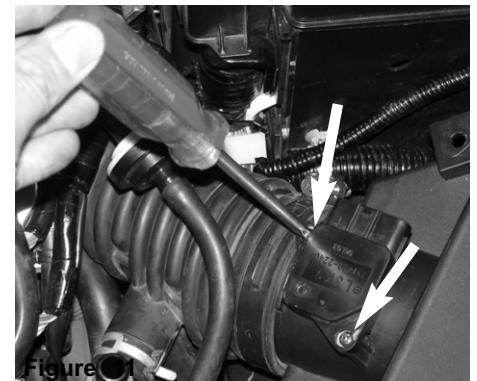

Figure 11
Loosen and remove the two mass air flow sensor screws from the mass air sensor.

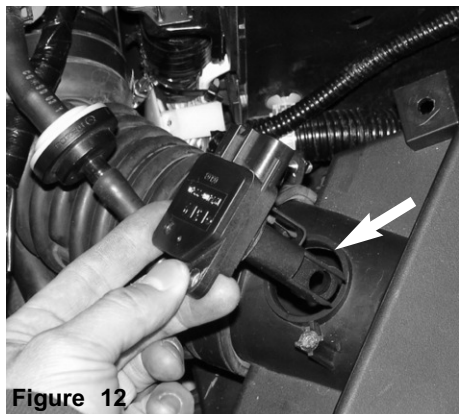

Figure 12
Once you have removed the screws continue to pull the mass air flow sensor from the sensor housing.

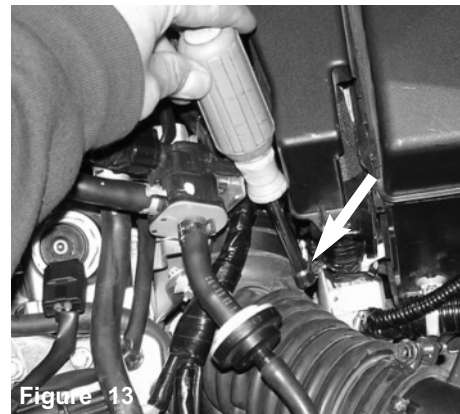

Figure 13
Loosen the clamp located over the air intake duct



Figure 14
The air box bolt is loosened from the lower air box as shown above.

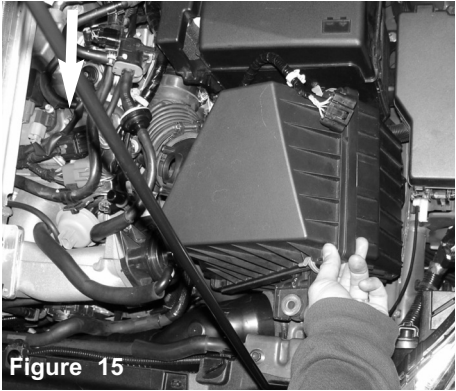

Figure 15

Once the bolt is removed continue to dislodge the air box from the grommets.

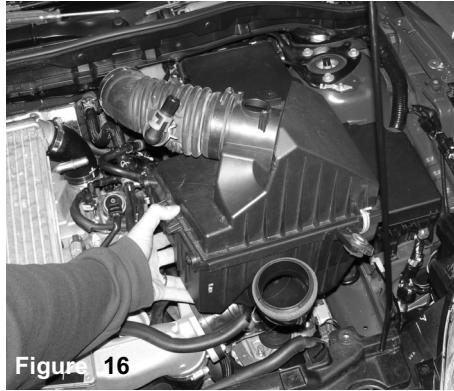

Figure 16

Once you have dislodged all stand-offs from the grommets, pull the air box cleaner out.

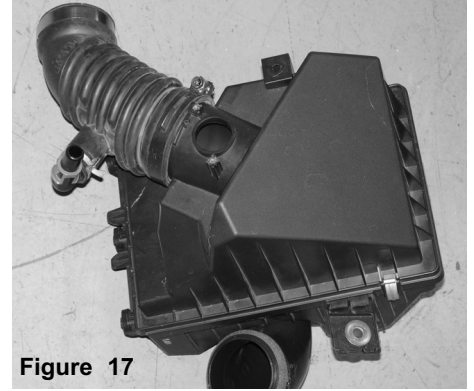

Figure 17

The air box cleaner is now out of the engine compartment.



Figure 18

The resonator duct is disconnected and pulled out of the engine compartment.



Figure 19

The air resonator duct is now removed.

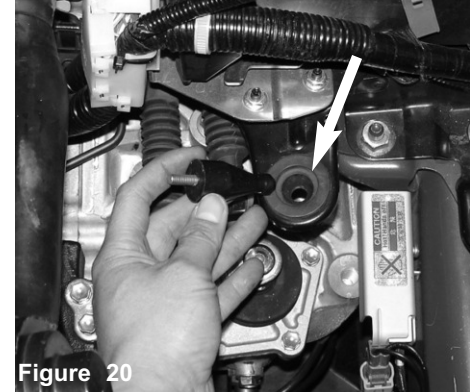

Figure 20

Insert the stand-off provided into the stock grommet and push down.

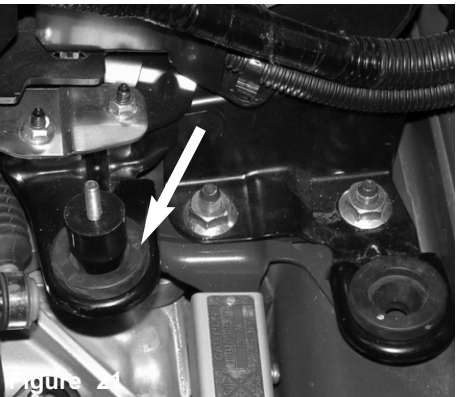

Figure 21

The stand-off is firmly pressed into the stock grommet.



Figure 22

Press the 2 1/2" end of the step hose over the turbo inlet.

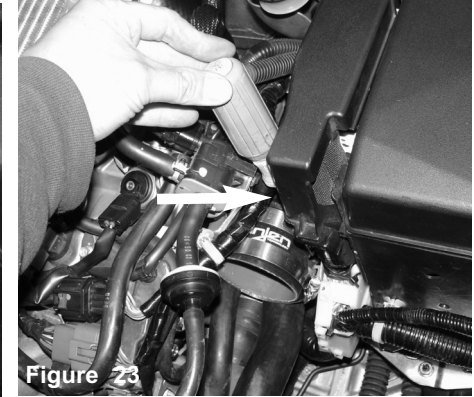

Figure 23

Once you have adjusted the step hose in place, continue to tighten the clamp.

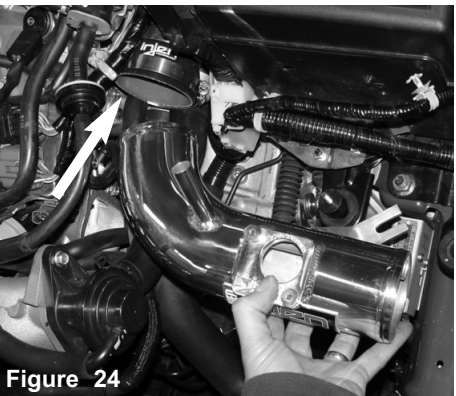

Figure 24

The primary intake is now lowered into the engine compartment. The upper intake is inserted into the three inch hose.

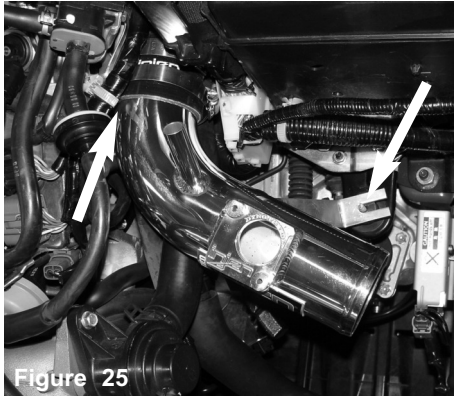

Figure 25

As the upper intake is inserted into the three inch hose, the intake bracket is aligned to the vibra-mount stud.



Figure 26

The intake bracket is sitting flush over the stand-off as shown above.

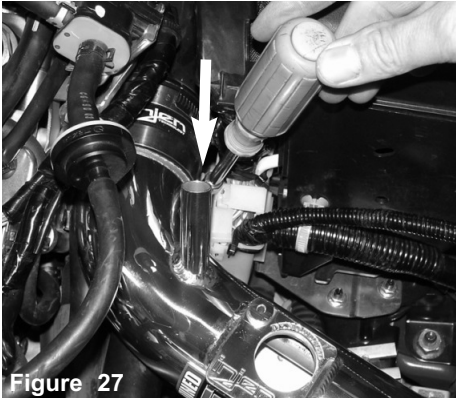

Figure 27

Once you have aligned the intake bracket to the stand-off, continue to tighten the hose clamp.

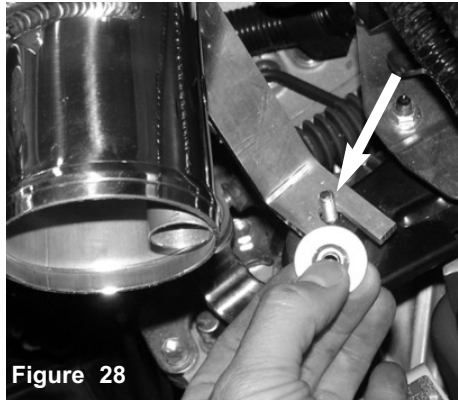

Figure 28

An m6 flange nut and washer is used to fasten the intake bracket to the stand-off.

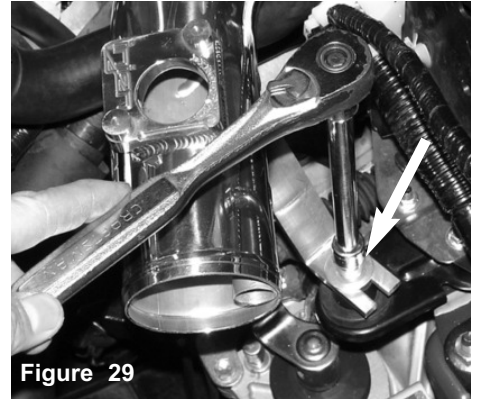

Figure 29

The intake is adjusted and the flange nut is tightened.



Figure 30

The 15mm hose is pressed over the intake vacuum port.

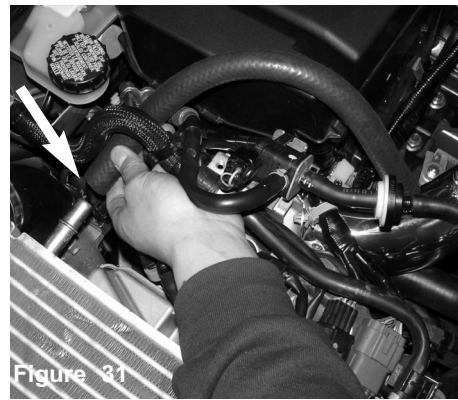

Figure 31

The other end of the 15mm hose is pressed over the crankcase vacuum port.

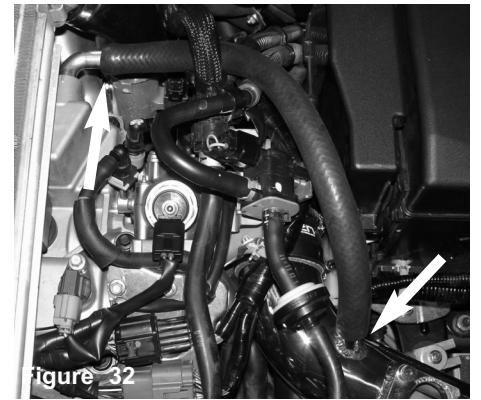

Figure 32

The 15"-15mm vacuum hose is now installed.

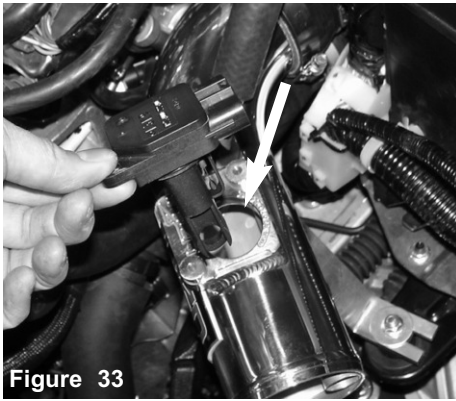

Figure 33

The mass air flow sensor is now ready to be inserted into the machined sensor adapter.



Figure 34

The 2- m4 screws are used to secure the mass air flow sensor.



Figure 35

An allen is used to tighten the two m4 screws over the mass air flow sensor.

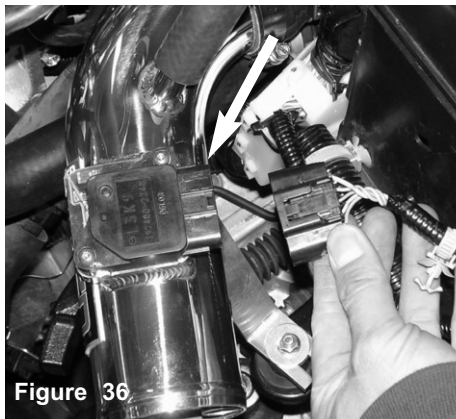

Figure 36

The harness clip is pressed in place until it snaps together with the mass air flow sensor.

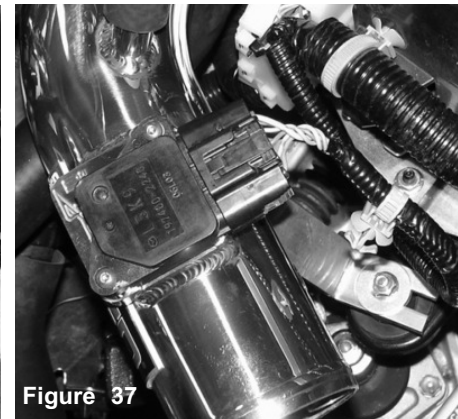

Figure 37

The harness clip is now installed.

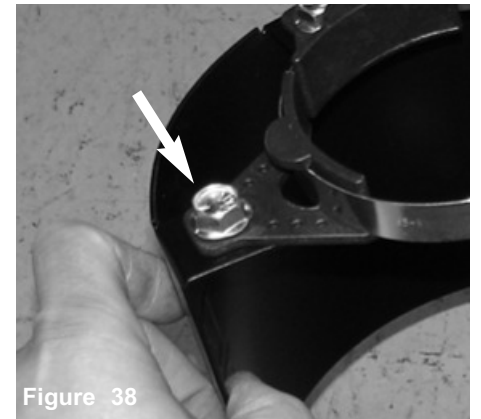

Figure 38

The composite clamp is aligned to the press nut over the heat shield and a 5/16 flange bolt is used to fasten the clamps in place.

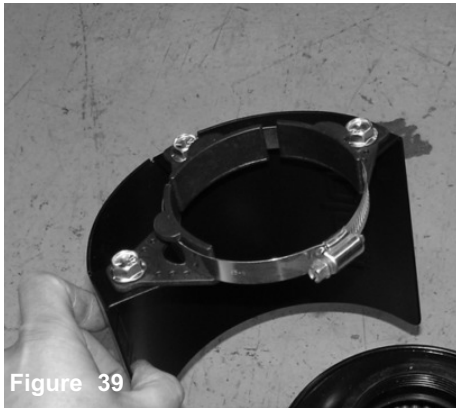

Figure 39

All three clamps and bolts are now installed. The filter clamp is removed and placed around the HS clamps.

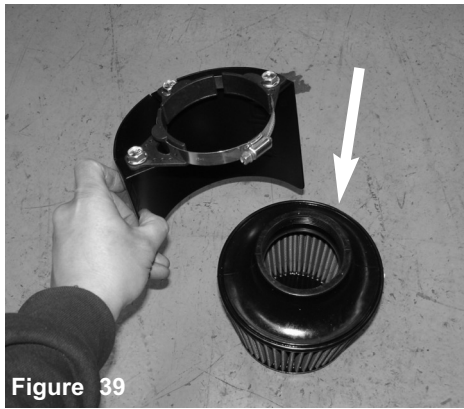

Figure 39

The assembled clamps and heat shield is now lowered over the filter.



Figure 40

The clamps are placed around the filter neck, do not over tighten the filter clamp at this time.



Fig 41

The bolt on the radiator bracket is loosened. The bracket is removed from the driver side top radiator.

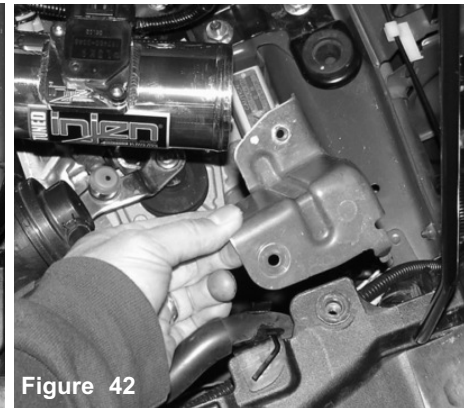

Figure 42

The bracket is now removed from the top radiator.



Figure 43

Align the assembled filter and heat shield over the end of the intake. The filter stop should be resting up against the intake end, now tighten the filter clamp.

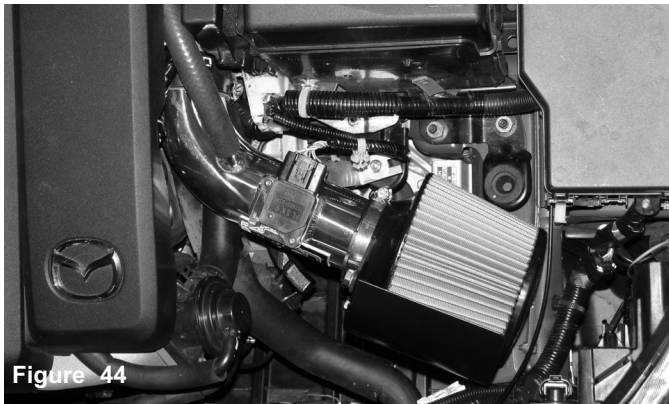

Figure 44

Congratulations! You have just completed the installation of one of the best air intake systems made. Once the intake and heat shield has been properly adjusted, continue to tighten all nuts, bolts and clamps.



Figure 45

Periodically, check the fitment of both intake systems. Normal driving conditions may loosen nuts, bolts and clamps causing intakes to shift resulting in damage to automotive parts.

1. Upon completion of the installation, reconnect the negative battery terminal before you start the engine.
2. Align the entire intake system for the best possible fit. Once the intake has been properly fitted continue to tighten all nuts, bolts and clamps.
3. Periodically, recheck the alignment of the intake system and make sure there is proper clearance around and along the length of the intake. Failure to follow proper maintenance procedures may cause damage to the intake and will void the warranty.
4. Start the engine and listen carefully for any odd noises, rattles and/or air leaks prior to taking it for a test drive. If any problems arise go back and check the vacuum lines, hoses and clamps that maybe causing leaks or rattles and correct the problem.
5. Check the filter for excessive dirt build up. Clean or replace the filter with an original Injen filter (can be bought on-line at "injenonline.com"). Congratulations! You have just completed the installation of the best intake system sold on the market. Enjoy the added power and performance of your new intake system.